

**WLG
INCUBATOR
YOUNG
ARTISTS
SHOW 2021**

ALYA HATTA | ANWAR SUHAIMI | SHIKA

12 OCTOBER - 13 NOVEMBER 2021



WLG INCUBATOR YOUNG ARTISTS SHOW 2021

Wei-Ling Gallery is pleased to announce the second installation of the WLG Incubator Young Artists Show, featuring Alya Hatta, Anwar Suhaimi, and Shika. As part of the mentorship this year, these three emerging Malaysian artists dedicated their time to exchange, explore, and create new possibilities to extend their practices, with Anurendra Jegadeva as their mentor. The WLG Incubator is an initiative by Wei-Ling Galleries that was launched as a platform to highlight and collaborate on projects with emerging Malaysian artists. It is dedicated to help artists create a sustainable art practice, which allows them to develop their confidence towards making art that is authentic, experimental and progressive. Through this Incubator, we hope to discover and nurture artists and projects, which are critical towards shaping the voice of the next generation.

Kicking off in 2020, the WLG Young Artists Collaborative Mentorship Program is an extension of the incubator program, which provides the opportunity for emerging artists to be advised and guided by an established artist. Every year, research is conducted to identify the next generation of young progressive artists from Malaysia. The identified group of artists are invited to submit their portfolios for consideration and selection. The shortlisted candidates are then involved in a two-tier interview process, whereupon 2 to 3 artists are selected for participation. Over a six-month program, these selected artists work with an established artist as their mentor to discuss, research, explore, experiment, and develop new concepts. This platform aims to provide a safe space for these artists to express the challenges they face in their professional and artistic practices, as well as to support them in the aspects that they choose to develop further. The results are presented through the WLG Incubator Young Artists Show at Wei-Ling Galleries, serving as a channel to introduce their work of art to a wider audience.

With the artists and their mentor based in different parts of the globe (Malaysia, the UK, Japan, and Australia) in the midst of the pandemic, this year's program saw them stepping into the new realities of our era.



What does it mean to connect in times of isolation? What new methods of working must an artist adapt to? These questions informed the artists' points of consideration when experimenting with new mediums, formats, and approaches. The outcomes of this mentorship are presented through this collective exhibition, which displays the results of their multidisciplinary techniques and thought-provoking ideas. Dealing with personal memories, questions of identity and perception, their works of art challenge the views that we are surrounded with in the present-day society.

On the first floor of the gallery, Alya Hatta's multicoloured paintings, monochromatic drawings and soft sculpture take us to moments that are personal to her, while addressing her feelings towards stereotypes. On the second floor, visitors are invited to witness Shika's internet culture-inspired pixel art, which she uses as a powerful tool of activism against injustices, especially in the context of Malaysia. Lastly, the exhibition takes us to Anwar's commentary on the ambiguity of a water tank as a utilitarian object; his minimalistic drawings were executed by a robot instructed by the artist - result of his experiment using physical computing technology. Akin to a journey, walking through these three different spaces offer us new ways of seeing, forcing us to rethink the values, beliefs, and presumptions that we might have been holding onto, all these times.

ALYA HATTA (B.1999)

Alya Hatta's multicoloured paintings take us to moments that are personal to her. Currently taking her Master's degree in painting at the Royal College of Art, most of the scenes depicted are of her life in London for the past 5 years. Thus, the questions of displacement, diaspora, and representation of her Asian identity are often addressed. In fact, the title of the series itself, '*Always Greener*' (2021) draws from the famous saying that "the grass is always greener on the other side", referring to her own migration to a foreign land. Dialoguing with her large-scale paintings are tiny canvas paintings which are stretched onto found objects such as a Panadol packaging, breaking the myth of what a painting should be. Alya's attempt in expressing personal experiences and the notion of secrecy also gives birth to a set of small and intimate pencil drawings on paper. For the first time, we see Alya's personage occupying the physical space of the audience in the form of a soft sculpture. With features that reflect the stereotypical appearance of an Asian woman, her body appears deconstructed and displaced.



Top:
Loser
Oil on canvas on plaster board
17.5cm x 13.7cm
2021



Bottom:
There
Oil, pencil and pastel on canvas on plaster board
16cm x 14cm
2021



Top:
Maryon
Oil, pencil and pastel on canvas on plaster board
13.5cm x 10.5cm
2021

Bottom:
Burnt Sugar
Oil on canvas on mystery novel
18cm x 11cm
2021



Top:
Ah, broad shoulders
Oil, pencil and pastel on canvas on panadol box
10.5cm x 7.5cm
2021



Bottom:
Slept on
Oil and pencil on canvas on plaster board
16cm x 13.5cm
2021



It was all jello
Oil on canvas
165cm x 210cm
2021



9 Toes

Oil on linen
170cm x 120cm
2021



A-Club

Oil on canvas
165cm x 130cm
2021



Why are they here?

Oil on canvas
152cm x 213cm
2021



ZZZZ

Oil on canvas
150cm x 170cm
2021



Its been 2 days. neck still hurts.
whiplash maybe -



Really, what does it all mean? Working hard,
for days have been sleeping like this. You can take
the wheel if you want. It's like how sleeping works,
one eye open, at least you decide to close it.

Top:
On a rollercoaster ride
Pencil on paper
12cm x 18cm
2021

Middle:
04:00
Pencil on paper
16.5cm x 20.5cm
2021

Bottom:
Night in
Pencil on paper
13cm x 14.5cm
2021





Top:
The boys
 Pencil on paper
 14cm x 14cm
 2021

Middle:
A serious talk
 Pencil on paper
 14cm x 14cm
 2021

Bottom:
Deflating
 Pencil on paper
 14cm x 14cm
 2021

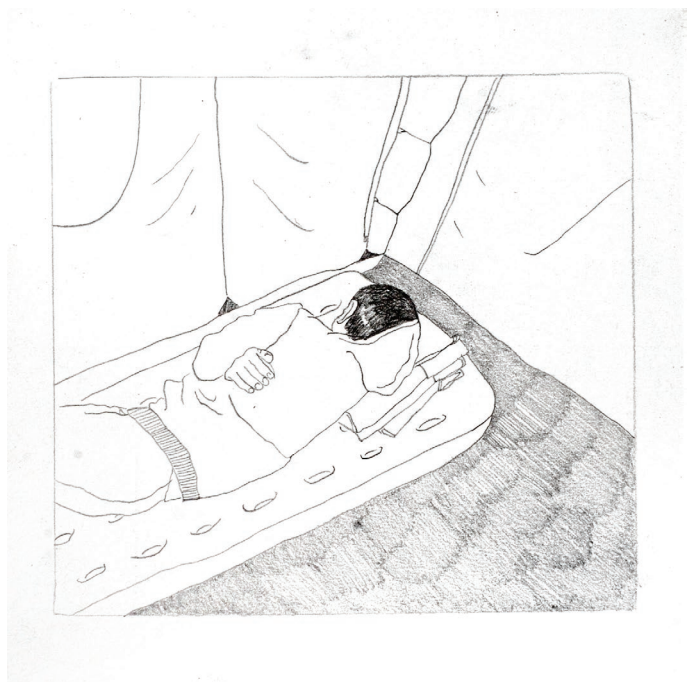

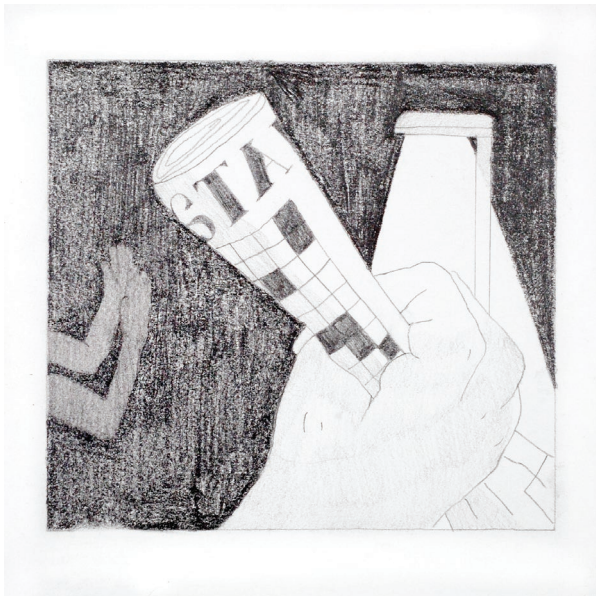

The Evening Standard (violence)

Pencil on paper

14cm x 14cm

2021



Family portrait.



Middle Left:
Family Portrait
Pencil on paper
14cm x 14cm
2021

Middle Right:
Here
Pencil on paper
14cm x 14cm
2021

Bottom:
Wetherspoons
Pencil on paper
10cm x 14cm
2021





Sleaze Cake
Inflatable
Variable dimensions
Est. 160cm x 160cm
2021



Alya Hatta's installation view

ANWAR SUHAIMI (B. 1987)

Anwar Suhaimi presents a series of monochromatic drawings executed by his self-built drawing robot, as the result of an experiment using physical computing technology, which he programmed to read instructions. This concept strongly echoes Anwar's overall practice which, with his background in Fine Arts and Technology, has always seen him manoeuvre between both worlds. Anwar digitally sketched the shape of a water tank, followed by programming his device to draw the exact same forms. The duality between what is machine-programmed and organic is yet again present through the imperfections of the lines despite it being executed using technology. 'The Water Tanks' (2021) series could be considered as a continuation of his past installation work *Delan (Ripplings)* (2019), which received the Jury Award in Bakat Muda Sezaman 2019. This time around, he challenges our manner of looking at a public utilitarian object. Drawing the water tank's different facades and layers, Anwar suggests the idea of it being an echo chamber; although a collective facility, one could only speculate what lies inside. Accompanying the drawings is a one-channel video unveiling the structure of the tank, realised using 3D modelling.

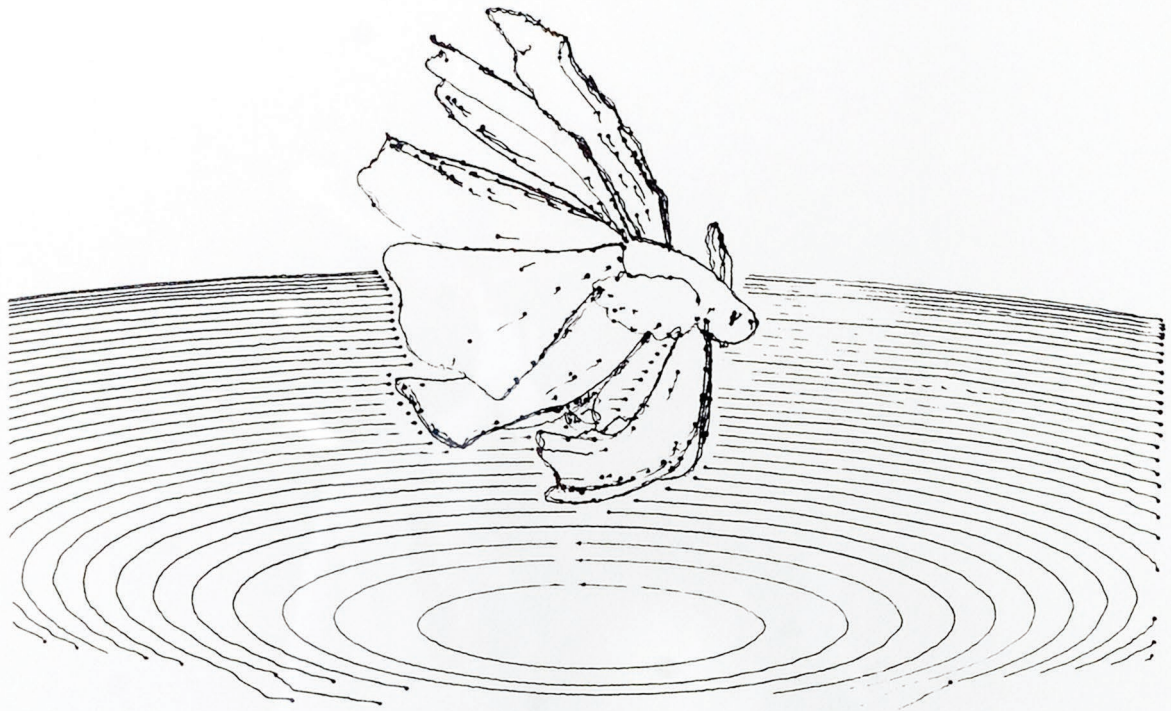
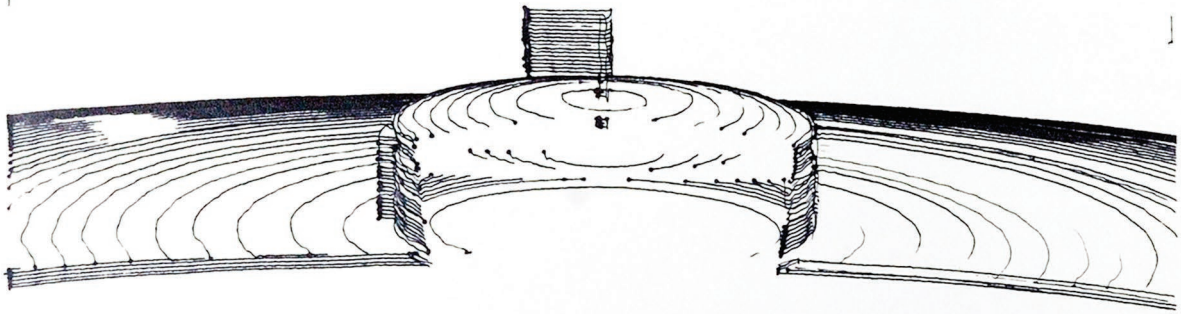

AMMAR 01

"Siamese Fighting Fish"

AMMAR 01

Siamese Fighting Fish
Ink on Awagami washi paper
55cm x 45cm
2021

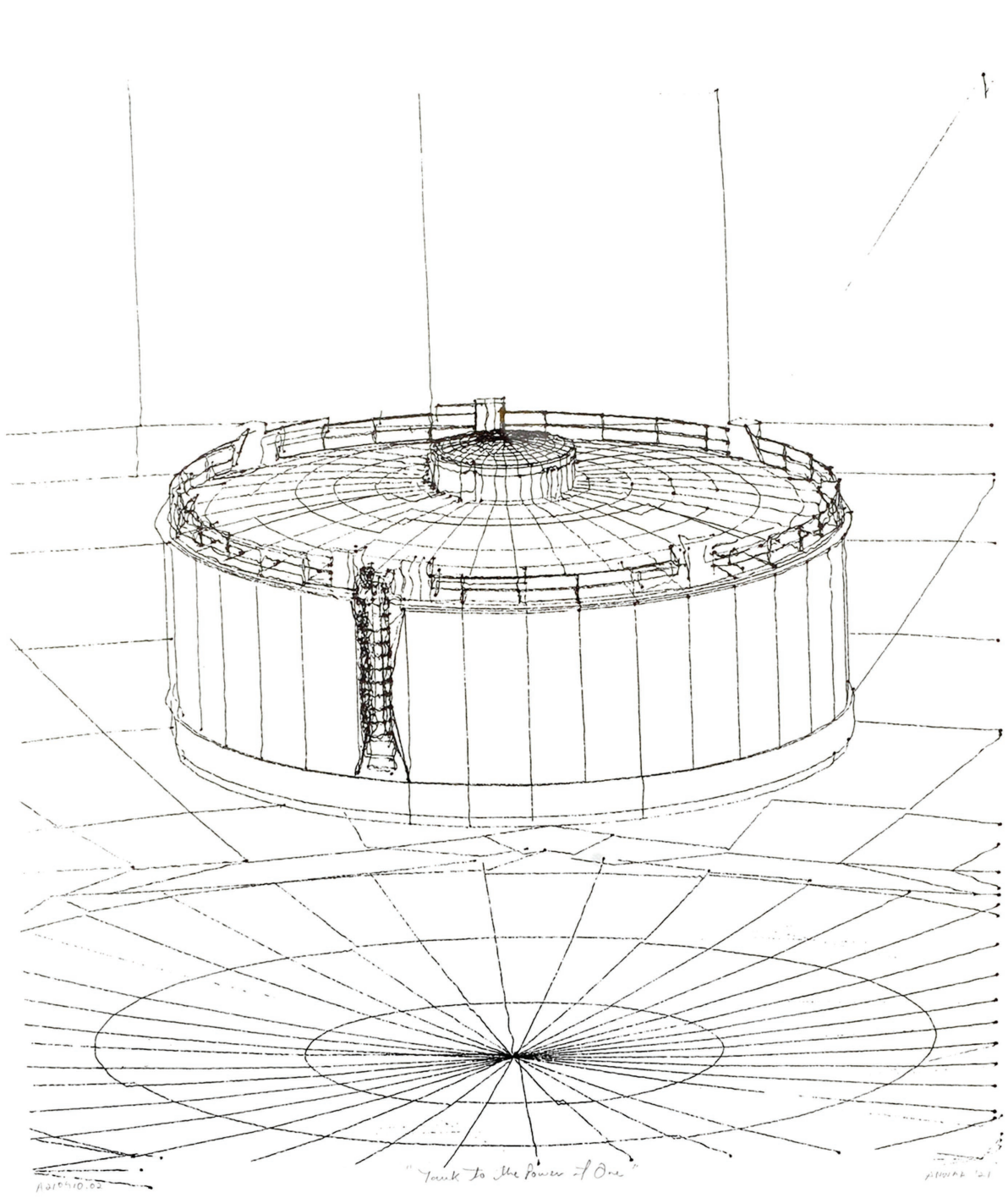

Tank to the power of One
Ink on Awagami washi paper
55cm x 45cm
2021

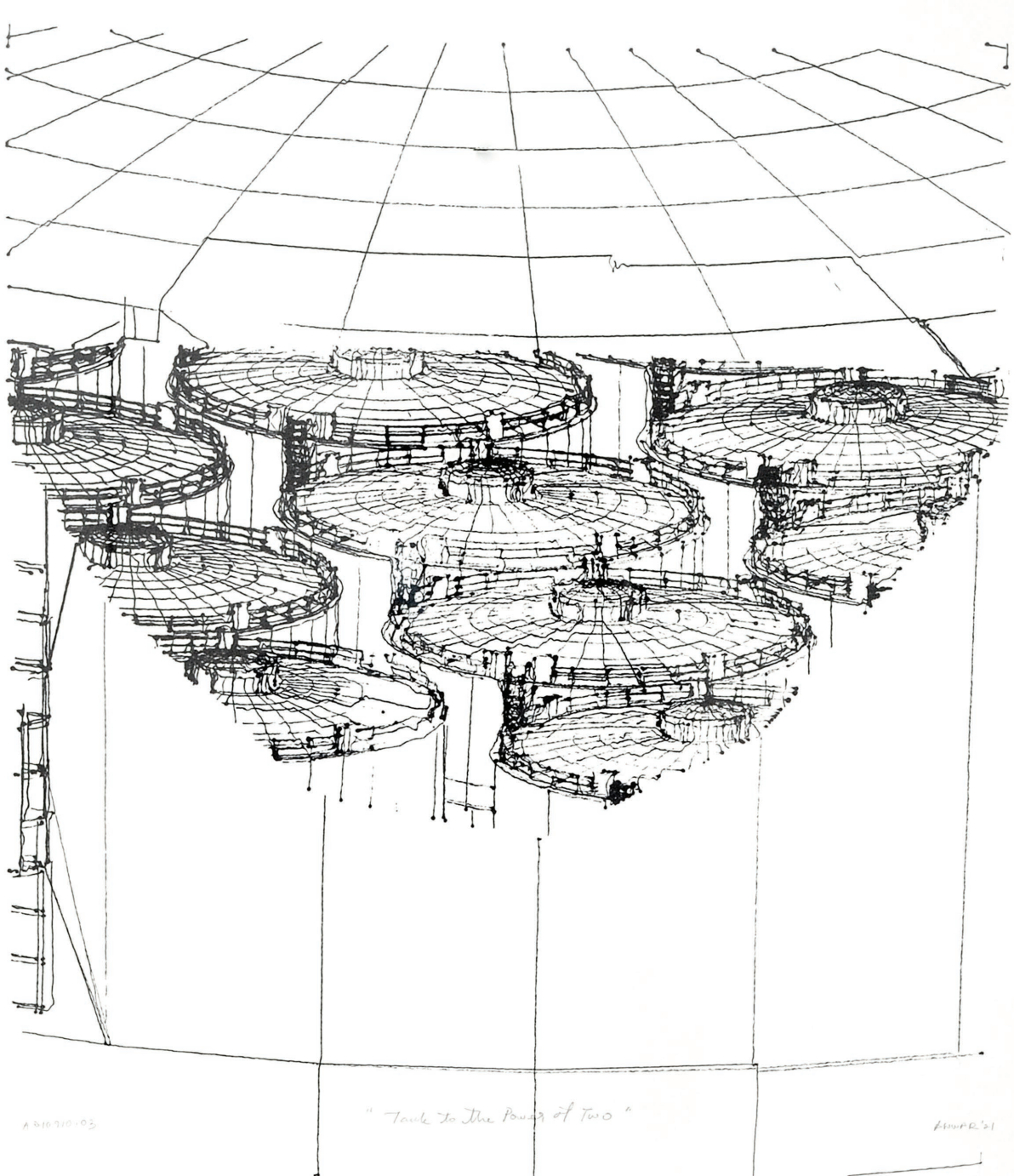

Tank to the power of Two
Ink on Awagami washi paper
55cm x 45cm
2021

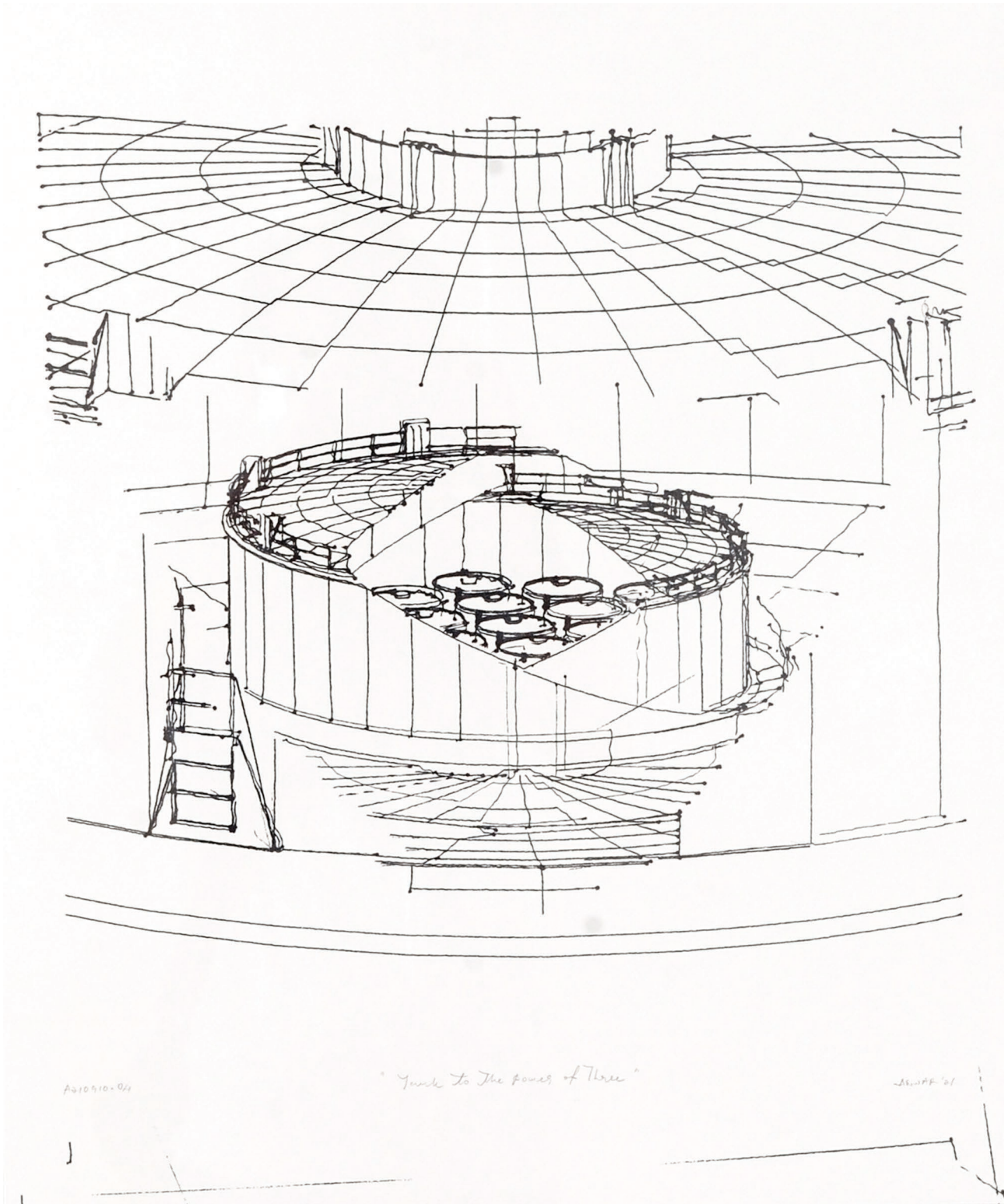

Tank to the power of Three
Ink on Awagami washi paper
55cm x 45cm
2021

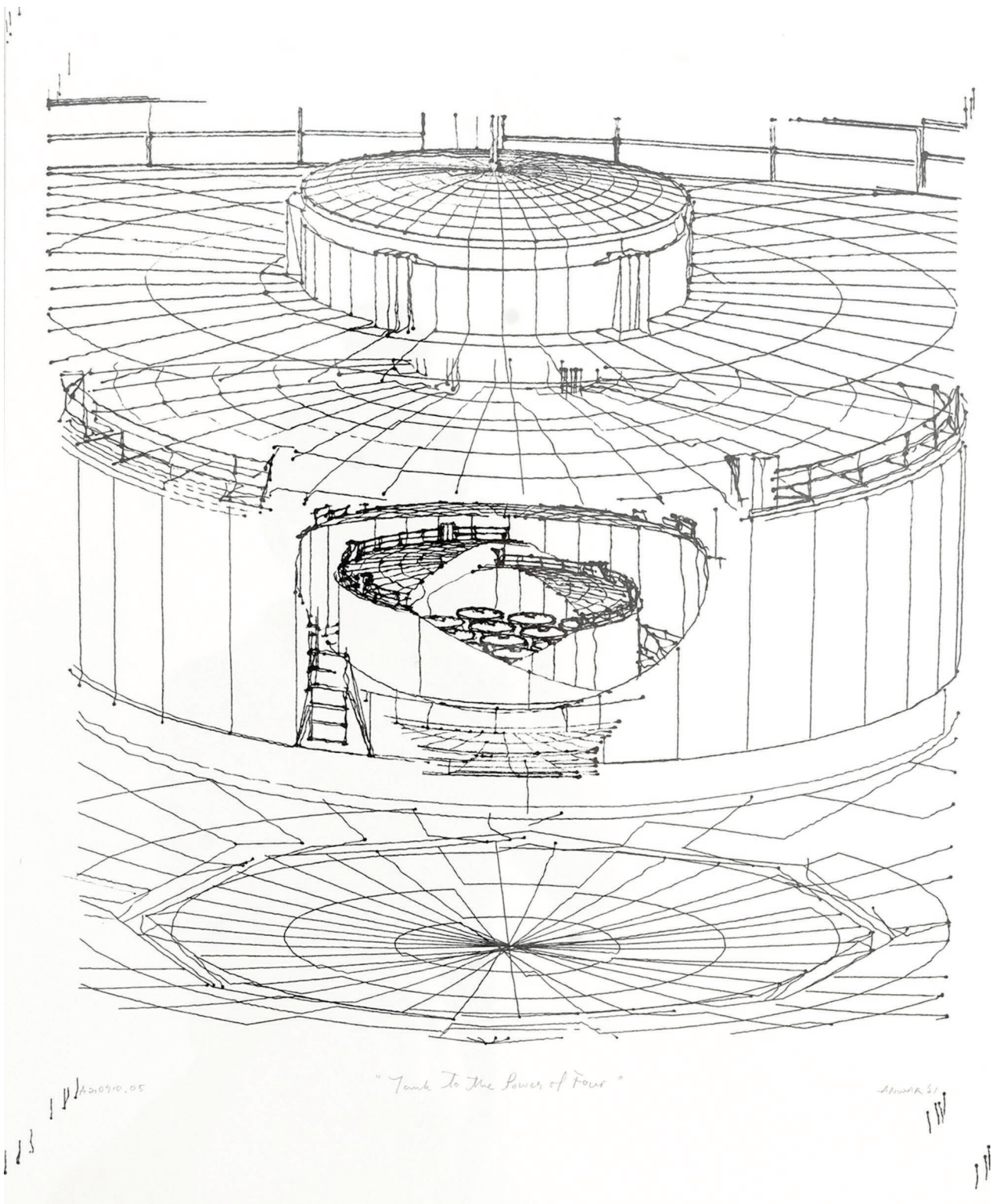

Tank to the power of Four
Ink on Awagami washi paper
55cm x 45cm
2021

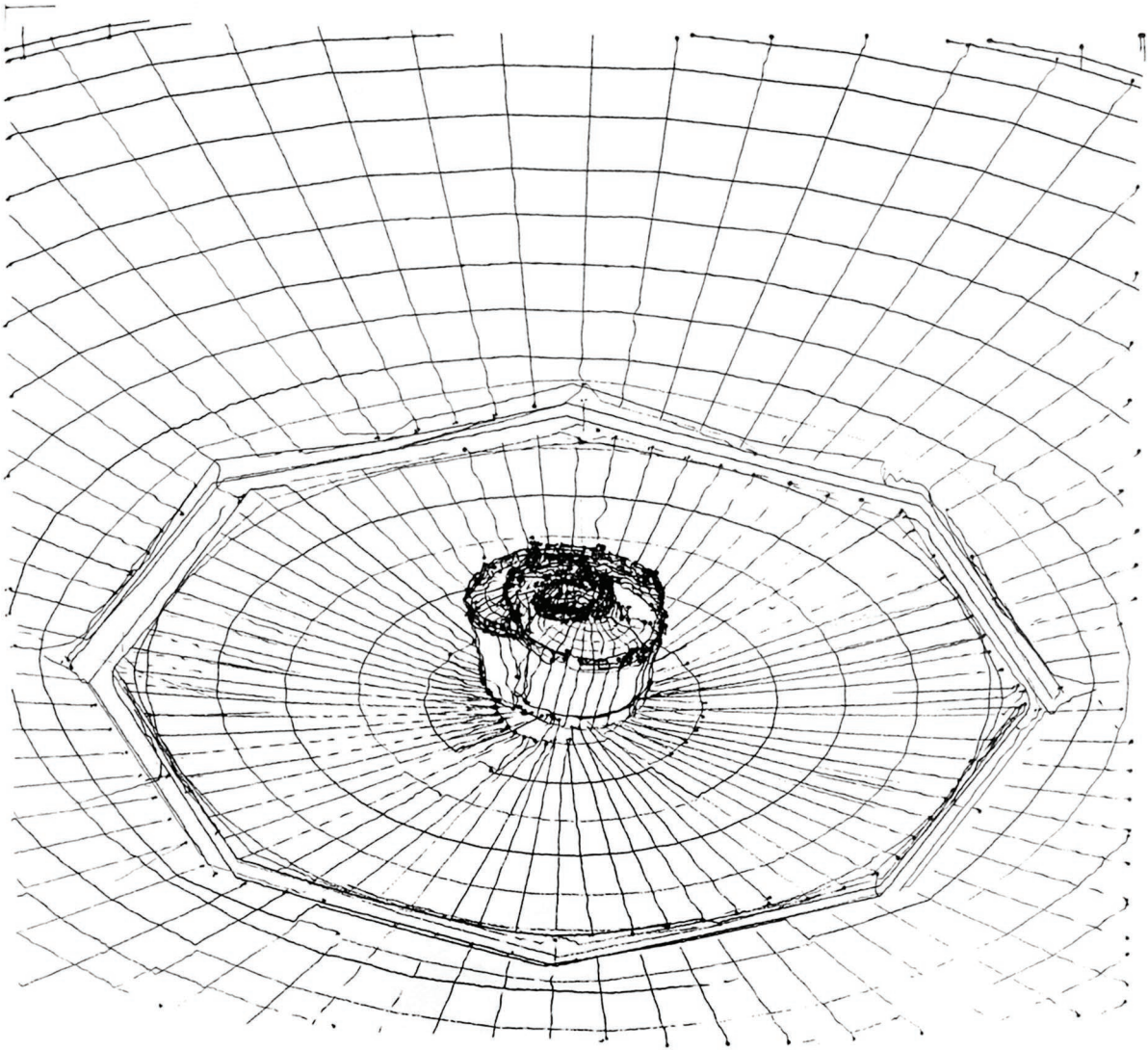

1210910.06

"Reservoir Bloom"

SHWAR'01

Reservoir Bloom

Ink on Awagami washi paper

55cm x 45cm

2021

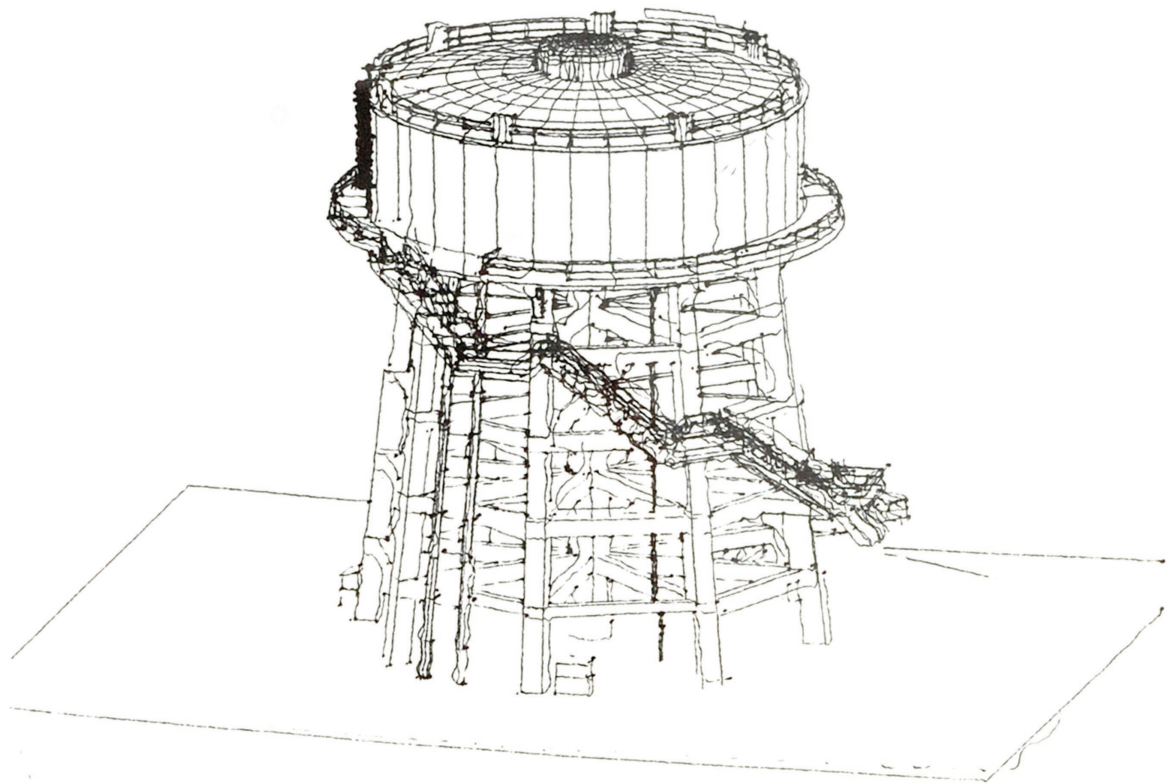

10/10/2021

"Structural Integrity"

10/10/2021

Structural Integrity

Ink on Awagami washi paper

55cm x 45cm

2021

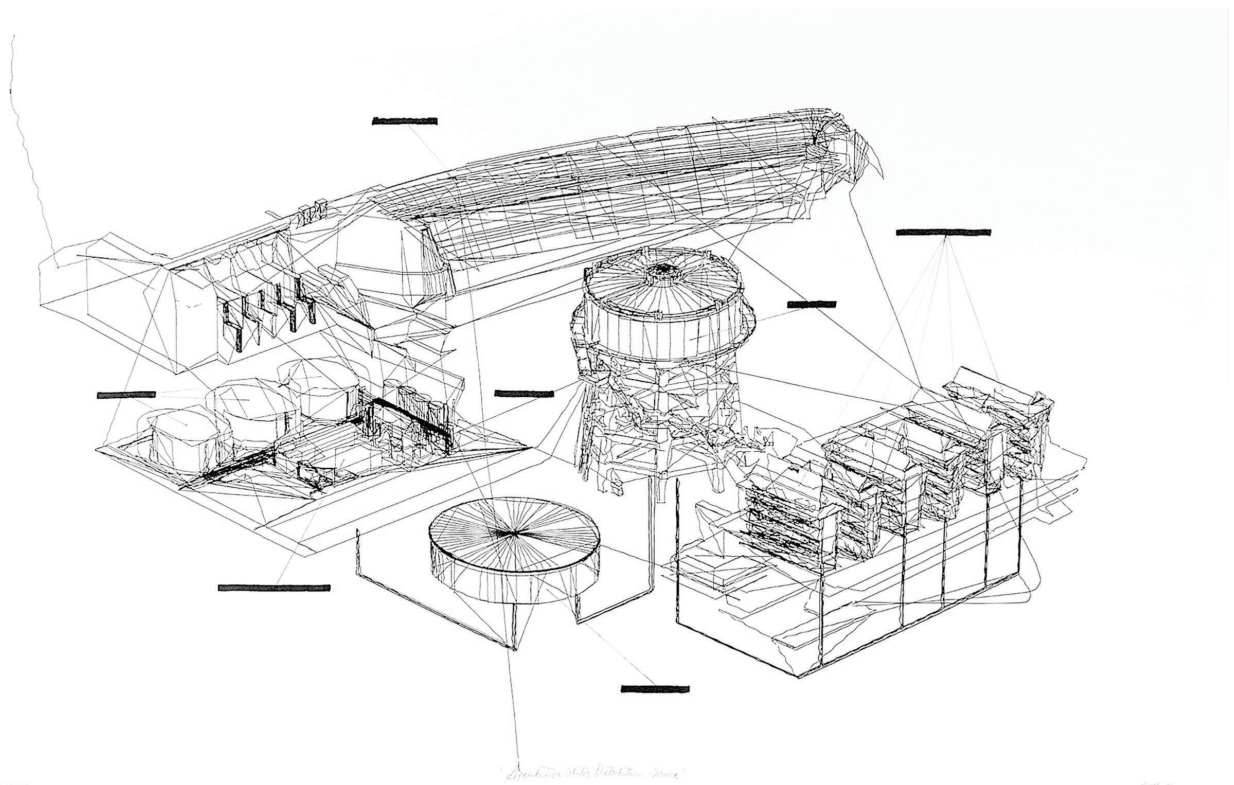

Speculative Water Distribution

Ink on 210gsm paper

77cm x 120cm

2021



Echo

Animation

5:45min, 1080p mp4 H.264

2021

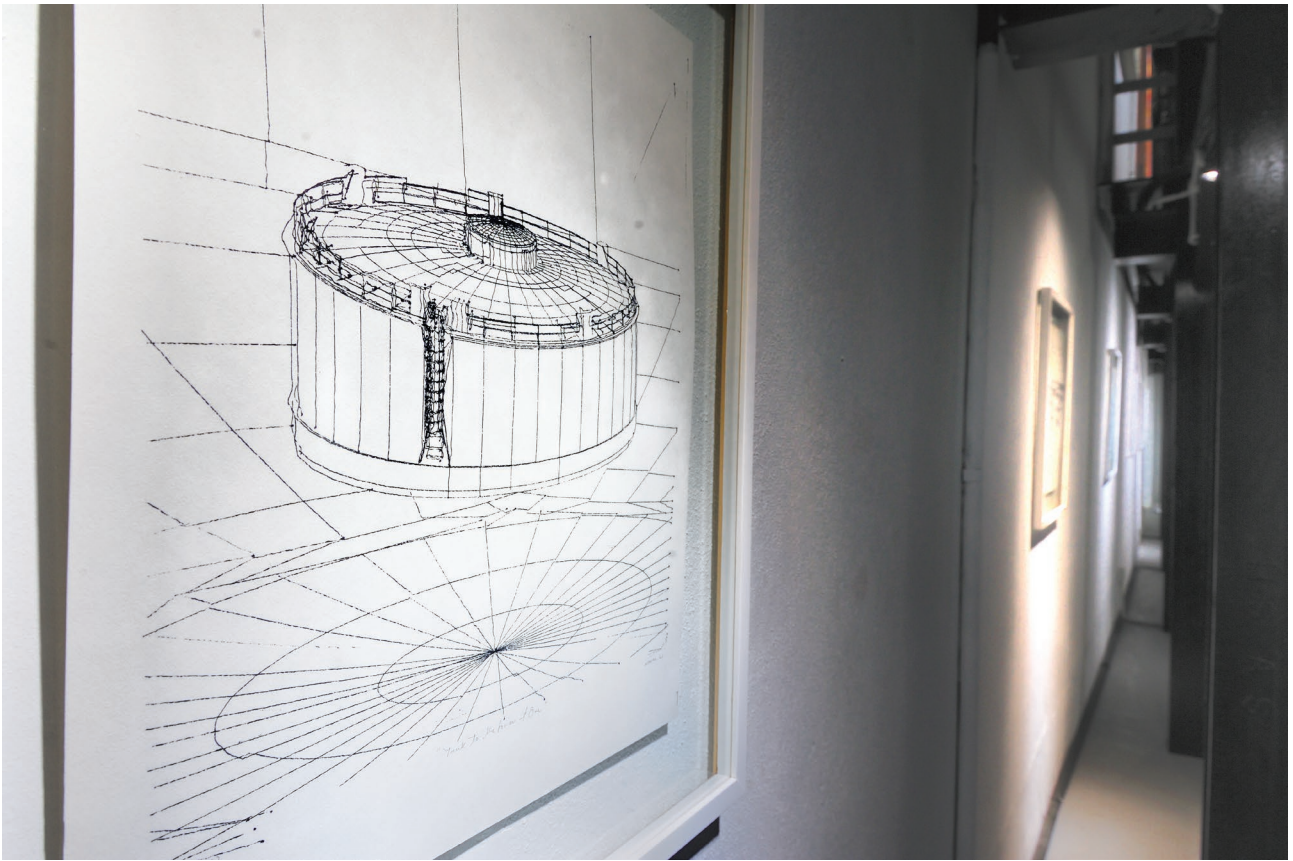

Anwar Suhaimi's installation view

SHIKA (B. 1976)

Pixel art started to gain relevance in the 1970s with the emergence of computers and digital art. Shika's fascination towards this phenomenon as well as the rise of the internet culture inspired her to use it as a tool of activism, mainly addressing the issue of transphobia. What is even stronger is her attempt of combining both the digital and physical space, through the act of printing and pasting her pixel art onto canvas. QR codes are also embedded onto these collages, so as to bridge visitors to the virtual realm. Throughout the mentorship, Shika focused on the research of colours and expressions, which gave birth to her digital illustrations, shared daily on her Instagram page. During the pandemic, Shika has pushed forward her digital activism further by utilising social media as a window to connect to the world. As she comments, "*This is the time when we all need to hang on to each other.*" The use of pastel colours is influenced by the new wave culture and electronic music, and serves as an irony as she tackles recent events in the local political landscape of Malaysia. Shika's critical work has been shown internationally, including at the Singapore Biennale and the Guangdong Times Museum.



Terimajelah (Binari)

Pixel art and collage on canvas

84cm x 59cm

2021



Terimajelah (Tetris)

Pixel art and collage on canvas

84cm x 59cm

2021



Syukur Aman 1

Pixel art and collage on canvas

35.5cm x 35.5cm

2019

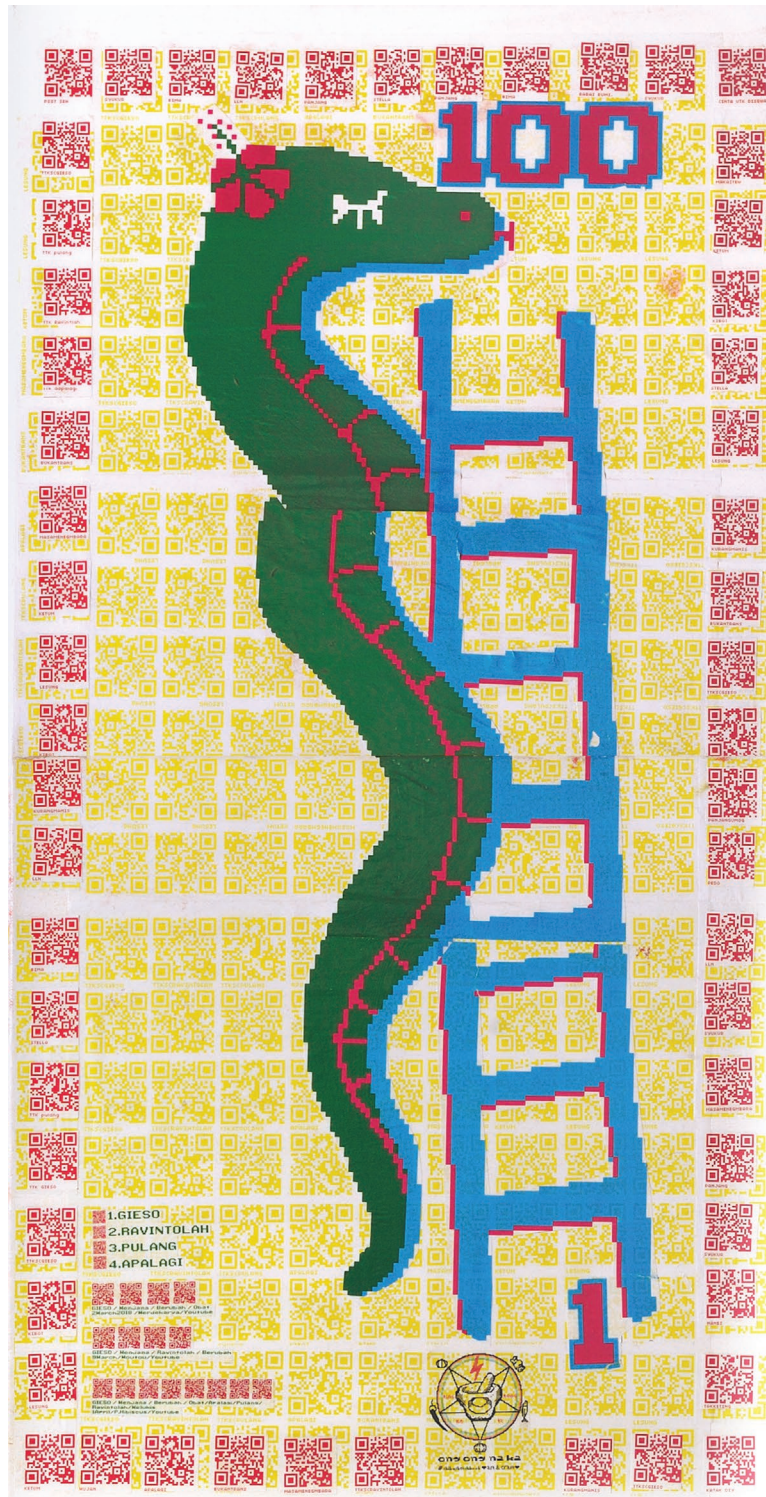

Turunaik, turunaik TingTong
Pixel art and collage on canvas
101cm x 51cm (Dptych)
2018



Top:
TingTong Nyah
 Pixel art and collage on canvas
 35.5cm x 35.5cm
 2018

Bottom:
Syukur Aman 2
 Pixel art and collage on canvas
 25cm x 21cm
 2018



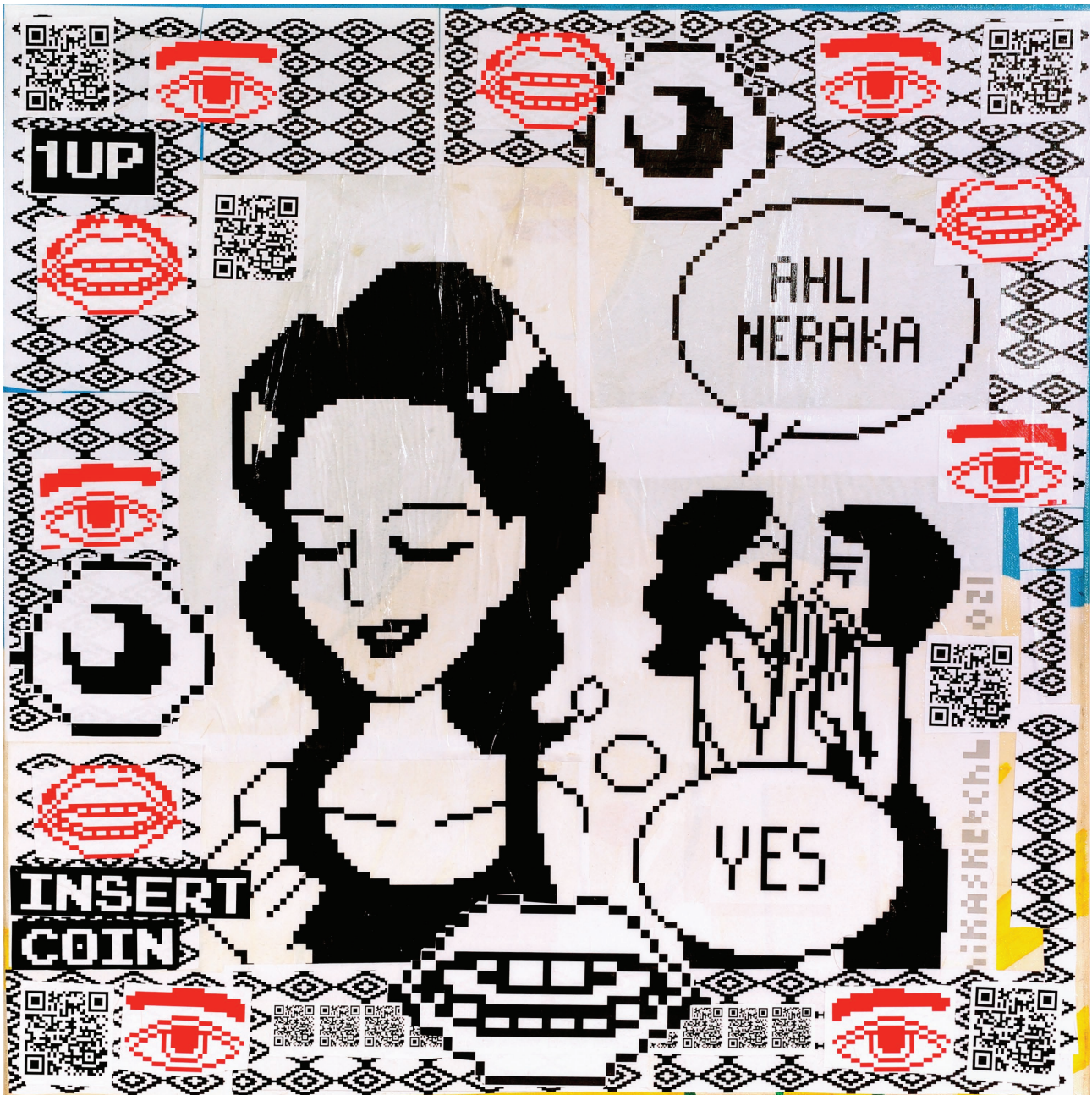

Ahli Neraka

Pixel art and collage on canvas

76cm x 76cm

2021



Terimajelah Blues

Pixel art and collage on canvas

56.5cm x 56.5cm

2021



Terimajelah (Masak)

Pixel art and collage on canvas

76cm x 76cm

2021



Malaysia Truly Transphobia
Digital pixel art (mp4)
20 seconds each
2021



Shika's installation view

List of Artworks

Alya Hatta

On a rollercoaster ride (2021) | Pencil on paper; 12cm x 18cm

Night in (2021) | Pencil on paper; 13cm x 14.5cm

04:00 (2021) | Pencil on paper; 16.5cm x 20.5cm

The boys (2021) | Pencil on paper; 14cm x 14cm

A serious talk (2021) | Pencil on paper; 14cm x 14cm

Deflating (2021) | Pencil on paper; 14cm x 14cm

The Evening Standard (violence) (2021) | Pencil on paper; 14cm x 14cm

Family Portrait (2021) | Pencil on paper; 14cm x 14cm

Here (2021) | Pencil on paper; 14cm x 14cm

Wetherspoons (2021) | Pencil on paper; 10cm x 14cm

Ah, broad shoulders (2021) | Oil, pencil and pastel on canvas on panadol box; 10.5cm x 7.5cm

Maryon (2021) | Oil, pencil and pastel on canvas on plaster board; 13.5cm x 10.5cm

There (2021) | Oil, pencil and pastel on canvas on plaster board; 16cm x 14cm

Burnt Sugar (2021) | Oil on canvas on mystery novel; 18cm x 11cm

Loser (2021) | Oil on canvas on plaster board; 17.5cm x 13.7cm

Slept on (2021) | Oil and pencil on canvas on plaster board; 16cm x 13.5cm

Sleaze Cake (2021) | Inflatable; Variable dimensions; Est. 160cm x 160cm

9 Toes (2021) | Oil on linen; 170cm x 120cm

A-Club (2021) | Oil on canvas; 165cm x 130cm

ZZZZ (2021) | Oil on canvas; 150cm x 170cm

It was all jello (2021) | Oil on canvas; 165cm x 210cm

Why are they here? (2021) | Oil on canvas; 152cm x 213cm

Anwar Suhaimi

Siamese Fighting Fish (2021) | Ink on Awagami washi paper; 55cm x 45cm

Tank to the power of One (2021) | Ink on Awagami washi paper; 55cm x 45cm

Tank to the power of Two (2021) | Ink on Awagami washi paper; 55cm x 45cm

Tank to the power of Three (2021) | Ink on Awagami washi paper; 55cm x 45cm

Tank to the power of Four (2021) | Ink on Awagami washi paper; 55cm x 45cm

Reservoir Bloom (2021) | Ink on Awagami washi paper; 55cm x 45cm

Structural Integrity (2021) | Ink on Awagami washi paper; 55cm x 45cm

Speculative Water Distribution (2021) | Ink on 210gsm paper; 77cm x 120cm

Echo (2021) | Animation; 5:45min, 1080p mp4 H.264

Shika

Terimajelah (Binari) (2021) | Pixel art and collage on canvas; 84cm x 59cm

Terimajelah (Tetris) (2021) | Pixel art and collage on canvas; 84cm x 59cm

Syukur Aman 1 (2019) | Pixel art and collage on canvas; 35.5cm x 35.5cm

Turunaik, turunaik TingTong (2018) | Pixel art and collage on canvas; 101cm x 51cm (Diptych)

TingTong Nyah (2018) | Pixel art and collage on canvas; 35.5cm x 35.5cm

Syukur Aman 2 (2018) | Pixel art and collage on canvas; 25cm x 21cm

Ahli Neraka (2021) | Pixel art and collage on canvas;; 76cm x 76cm

Terimajelah Blues (2021) | Pixel art and collage on canvas; 56.5cm x 56.5cm

Terimajelah (Masak) (2021) | Pixel art and collage on canvas; 76cm x 76cm

Malaysia Truly Transphobia (2021) | Digital pixel art (mp4); 20 seconds each

ALYA HATTA (B.1999)

EDUCATION

- 2023 MA Painting, Royal College of Art, London, United Kingdom
- 2021 BA Fine Art, Goldsmiths University of London (Neville Burston Award for Painting)

SOLO EXHIBITIONS

- 2020 Playground, ZHAN Art I Space, Selangor, Malaysia
- 2017 Aphrodisia, Minut Init Gallery, Kuala Lumpur, Malaysia

SELECTED GROUP EXHIBITIONS

- 2021 WLG Incubator Young Artists Show 2021, Wei-Ling Gallery, Kuala Lumpur, Malaysia
- Goldsmiths BA Fine Art Degree Show, London, United Kingdom
- In Other Company, Deptford X Festival, London, United Kingdom
- Unity, We Are Filamen, KongsikL, Kuala Lumpur, Malaysia
- 100 Pieces: Art for All, Wei-Ling Contemporary, Kuala Lumpur, Malaysia
- 2020 Misplaced, Oped Space, Tokyo, Japan
- RRRAWRRR!!! Women Artist Exhibition, Maybank Art Gallery, Kuala Lumpur, Malaysia
- Lava Club Experience, Mercato Metropolitan, London, United Kingdom
- 2019 SH/FT, Blackbox Publika, Kuala Lumpur, Malaysia
- Snakes and Ladders, The Incubator, Kuala Lumpur, Malaysia
- GENERATE! Festival, Tubingen, Germany
- Third Nature, Safehouse 2, London, United Kingdom
- Sotheby's Institute of Art Student Charity Auction
- 2018 Goldsmiths Festival of The Arts

COLLABORATIONS

- 2021 JW Anderson Custom Sneaker Commission
- 2020 DAZED Magazine New Gen GAP Commission

ANWAR SUHAIMI (B. 1987)

EDUCATION

- 2012 – 2014 M.A. in Fine Art & Technology, University of Technology Mara, Malaysia
2005 – 2009 B.A. in Media Innovation, Multimedia University, Cyberjaya, Malaysia
2001 – 2004 Royal Military College, Kuala Lumpur, Malaysia

GRANTS & AWARDS

- 2020 ASM ArtScience First Prize 2020, Group Participation, Academy of Sciences Malaysia.
2019 Jury Award, Bakat Muda Sezaman 2019 (Young Contemporary Award 2019), National Art Gallery, Malaysia.
Best Music Video 2008, 'Faith' by Seven Collar T-Shirt, Festival Film Pelajar 2008, FINAS
2006 TM Scholarship, Telekom Malaysia Foundation.

SELECTED PROJECTS & EXHIBITIONS

- 2021 WLG Incubator Young Artists Show 2021, Wei-Ling Gallery, Kuala Lumpur, Malaysia
100 Pieces: Art for All, Wei-Ling Gallery, Kuala Lumpur, Malaysia
2020 Useless, Suma Orientalis, Petaling Jaya, Malaysia
A Change Parade, 2020 - Ongoing, Kuala Lumpur, Malaysia
Digital Tropical: Breathing Waves, 2020, Universiti Kebangsaan Malaysia, Selangor, Malaysia
2019 Malaysia - Singapore Triennial Cultural Showcase 2019, Kuala Lumpur, Malaysia
IVIC19 Institute of Visual Informatics Conference 2019, Universiti Kebangsaan Malaysia, Selangor, Malaysia
Drawing Matter?, HOM Art Trans, Kuala Lumpur, Malaysia
NYAWA'19, Universiti Putra Malaysia, Selangor, Malaysia
M...Reinterpreting Minimalism, Segaris Art Center, Kuala Lumpur, Malaysia
Harumanis, Akademi Seni Kebangsaan Malaysia, Kuala Lumpur, Malaysia
Bakat Muda Sezaman 2019, Balai Seni Visual Negara, Kuala Lumpur, Malaysia
Past in Plastic: Present Artefacts, Suma Orientalis, Petaling Jaya, Malaysia
Only Connect Osaka, Creative Center Osaka, Osaka, Japan
2018 Bintang 5, Segaris Art Center, Kuala Lumpur, Malaysia
They Say I Can't Paint, Suma Orientalis, Petaling Jaya, Malaysia
2017 Festival Lampu Putrajaya 2017, Putrajaya, Malaysia
2016 The Practitioners, Segaris Art Center, Kuala Lumpur, Malaysia
Jelajah Kampus, Ministry of Youth, Malaysia
2015 Festival Lampu Putrajaya 2015, Putrajaya, Malaysia
2014 Festival Lampu Putrajaya 2014, Putrajaya, Malaysia
2013 Young Masters, Segaris Art Center, Kuala Lumpur, Malaysia
VGA Fest 2013, Publika Kuala Lumpur, Malaysia
2012 Mull, Debauch to Kuala Lumpur (Component Two), The Actors Studio Lot 10, Kuala Lumpur, Malaysia
2011 Melbourne Burning Man Compression 2011, Revolt Melbourne Artspace, Melbourne, Australia
2009 SENS-OR Group Exhibition, KL Design Week 2009, Kuala Lumpur, Malaysia
2007 The Champion of Pahang's Lake Chini, DiGi's Amazing Malaysians, Pahang, Malaysia
2006 Art for Community Project, Ministry of Women, Family and Community Development, Selangor, Malaysia



CREDITS

2016 The Bomb Listener. Documentary, Montage & Graphic, Produced by FactualTV for History Channel

2012 Malaysia Revisited. Documentary. Montage & Graphic. Directed by Leong Hon Yuen, Produced by Red Comm for History Channel

ARTIST IN RESIDENCE

2019 YAE! Extend, Malaysia – Singapore Artist Residency Programme 2019, Malaysia

BIBLIOGRAPHY

SELECTED CATALOGUES

2019 Bakat Muda Sezaman - Young Contemporaries 2019. Malaysia: National Art Gallery, 2019

2016 The Practitioners - The Working Studio, Segaris Art Centre, 2016

SHIKA (B.1976)

SOLO EXHIBITION

2016 First solo exhibition ranging works from 2008 – 2016, Kerbau works studio in Bangsar, Kuala Lumpur, Malaysia

SELECTED GROUP EXHIBITIONS

- 2021 WLG Incubator Young Artists Show 2021, Wei-Ling Gallery, Kuala Lumpur, Malaysia
100 Pieces: Art for All, Wei-Ling Gallery, Kuala Lumpur, Malaysia
Human-Rights-In-Asean-Cartoonists-Perspective, Craftora, online virtual exhibition
shikasketchbook, Opensea, online virtual exhibition
Anthology of metaverse, online virtual exhibition, curated by James Ly
Group exhibition, GhuangZhou China, collaboration with curator Simon Soon & Roger Nelson, Guangdong Times Museum, Guangzhou China
- 2019 Artist talk / Malaysia Design Archive, Zhong San, Kuala Lumpur, Malaysia
What are you afraid of? , Curated by Sharmin Parameswaran, Backroom Gallery, Zhong San, Kuala Lumpur, Malaysia
Abort the Stigma, REXKL, Kuala Lumpur, Malaysia
- 2018 Lagi-lagi Bayi Terbuang mini solo exhibition, Pink Hibiscus, Zhong San, Kuala Lumpur, Malaysia
- 2017 Intersection (mini exhibition), curated by Perpetuum Mobile, co-organised by HIAP (Helsinki International Artist Program) Funded by Helsinki City Culture Office, event co-funded by The Finnish Culture Found (Suomen Kulttuurirahasto), Myymala2 Gallery/space, Helsinki, Finland
- 2017 FemF Art group exhibition, 3rd Space Gallery, Helsinki, Finland
The AR PAVILION – Madrid: COLLATERAL II
An exhibition at MATADERO Madrid by Perpetuum Mobile (PM) in the context of Transeuropa, Co-Funded by the Creative Europe Programme of the European Union. Curated by Ivor Stodolsky and Marita Muukkonen of PM, Matadero, Madrid, Spain
HIAP Open studio, Suomenlinna Helsinki, Finland
Human exhibition, Mural/artist talk, Nordisk KulturKontakt, Helsinki, Finland
Artist at Risk program/, Perpetuum Mobile
Artist at risk residency / HIAP, Suomenlinna, Helsinki, Finland
Mural, artist talk, exhibitions <http://www.hiap.fi/artist/shieko-reto>
- 2015 Artist / Volunteer / Curator
The Art of Giving: Nobody Gets Left Behind exhibition, Black Box Publika, Kuala Lumpur, Malaysia
Peasants & proletariats group exhibition, Curate by Tan Sei Hon, Xin Art Space, Kuala Lumpur, Malaysia
- 2014 Transmission Exhibition2, Akta Community Center, Shinjuku, Japan
Asian Public Intellectuals program / Nippon Foundation 2013/2014
Transmission Exhibition1, ICU (International Christian University) Public library, Japan
Asian Public Intellectuals program / Nippon Foundation 2013/2014
'If the world changed', Singapore Biennale 2013, Singapore Art Museum, Singapore
- 2013 Apa Cerite group exhibition, Black Box Gallery, Publika, Kuala Lumpur, Malaysia
- 2012 Makanlah Buah-buahan Tempatan, Publika, Kuala Lumpur, Malaysia
Nike Cortez 40th anniversary exhibition, art direction & installation, Juice KL, Kuala Lumpur, Malaysia



- 2010 Visual exhibition: “IndigNation6 visual art exhibition, Attic/My ArtSpace, Singapore
Al-Kesah/Once upon a time in Malaysia, group exhibition for Map Arts Festival @
Map KL in White Box Gallery Publika, Kuala Lumpur, Malaysia
Kuala Lumpur Dreaming: A group exhibition by the Annexe Gallery, Central Market
Kuala Lumpur, Malaysia
Vans Malaysia, Sunway Pyramid, Illustrations and live paintings on skateboards
organised by Vans and Wheel Love skateshop at Subway Pyramid, Malaysia
- 2009 Joint-Action-Group for Gender Equality, Mural and live performances for Projek
Sentuh. A 16 days violence against women campaign organised by J.A.G, Shah
Alam, Malaysia
Wheel Love skateshop Subang, Exterior mural art for Wheel Love skateshop,
Subang Jaya, Malaysia
- 2008 Dell Malaysia, Pavilion shopping center, Dell Christmas display (Reindeer Sculpture
paintings) at the Curve Shopping Center, Malaysia
Zouk Kuala Lumpur, Live Street party graffiti paintings / mural for Zouk organised by
Streething, Malaysia
- 2007 Toyota Capital Malaysia Sdn. Bhd, Live paintings on Toyota Vios fiberglass car
model, official launch event, The Curve, Malaysia
Let’s Art Move U (LAMU) organised live mural art paintings with fellow artists
Orkibal & Tha-B, KTM Berhad, KL.Sentral, Malaysia
Adidas Malaysia, KLCC Adidas flagship store mural, Malaysia
- “ Throw Up - our Lab’ group exhibition, *scape Gallery, National Youth Council
Singapore. Graffiti art exhibition, National Youth Council Singapore



Wei-Ling Gallery

Produced by Wei-Ling Gallery

To accompany the exhibition entitled '*WLG Incubator Young Artists Show 2021*'
from 12th October - 13th November 2021

Wei-Ling Gallery

No. 8 Jalan Scott, Brickfields
50470 Kuala Lumpur, Malaysia
T: +603 2260 1106 F: +603 22601107
E: weilinggallery@gmail.com
W: www.weiling-gallery.com

Wei-Ling Contemporary

RT-01, 6th Floor, The Gardens Mall,
Mid Valley City, Linkaran Syed Putra,
59200 Kuala Lumpur, Malaysia
T: +603 2282 8323
E: weilingcontemporary@gmail.com

PROJECT DIRECTOR | Lim Wei-Ling

DESIGNED BY | Lim Siew Boon

Copyright © 2021 Wei-Ling Gallery

All rights reserved. No part of this publication can be reproduced or transmitted in any form or by any means, electronic or mechanical, including photocopying, recording, or any other information storage and retrieval system without prior in writing from the publisher.